

# MODEL DVR8550

## 8.5 HP VACUUM SYSTEM

TWELVE (12) FILTER BAGS WITH  
52.8 SQ FT FILTER AREA

LARGE, EASY ACCESS  
FILTER SERVICE DOOR

SUPER EFFICIENT  
FILTRATION

FILTER CONDITION  
INDICATOR GAUGE

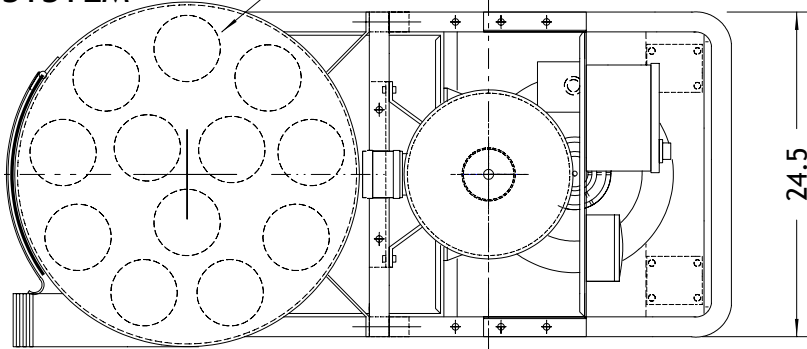

EFFECTIVE  
FILTER BAG  
SHAKER

FILTERS NEVER  
NEED CLEANING  
AS THE CANISTER  
FILLS.

OPTIONAL HEPA  
FILTER WITH  
CONDITION  
INDICATOR

OVERHEAD  
CRANE LIFT  
HOOKS

4" NPT  
INLET WITH  
INTERNAL  
WEAR STRIP

29.8 US GAL  
STORAGE DRUM

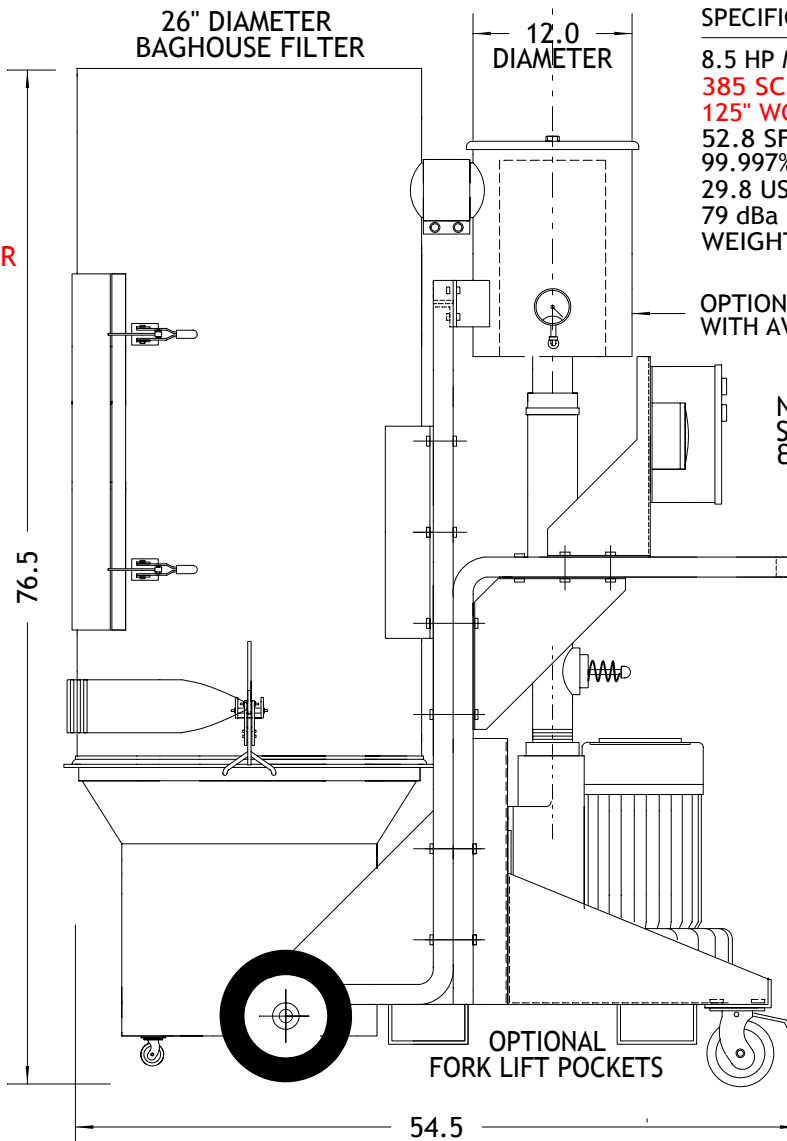

### SPECIFICATIONS:

- 8.5 HP MOTOR (VOLTAGE TO SUIT)
- 385 SCFM MAX
- 125" WG MAX VACUUM
- 52.8 SF FILTER BAGS
- 99.997% @ 0.4 MICRON EFFICIENT
- 29.8 US GALLON STORAGE DRUM
- 79 dBa NOISE LEVEL
- WEIGHT 570 LBS

OPTIONAL INLINE FILTER  
WITH AVAILABLE HEPA UPGRADE

NEMA 4  
STARTER PANEL  
& DP GAUGE

VACUUM GAUGE  
& RELIEF VALVE  
STANDARD

HEAVY DUTY ALL  
STEEL FRAME

8.5 HP  
QUIET, DEPENDABLE  
VACUUM PRODUCER

EFFECTIVE, BUILT-IN  
SILENCER

LOCKABLE  
5" SWIVEL CASTERS

OPTIONAL  
FORK LIFT POCKETS

			DATE:	FEB 2004	NORTHWIND AIR SYSTEMS BRAMPTON, ONTARIO
			DRAWN BY:	KRW	
			SCALE:	N.T.S.	
0	FEB 04	ISSUED FOR REVIEW	DRAWING No.	Rev.	<b>DuroVac</b> <b>DVR8550</b>
No.	DATE	REVISIONS	4060333 - 01	00	