

# MODEL DVR602

## 6.1 HP VACUUM SYSTEM

SEVEN (7) FILTER BAGS WITH  
30.8 SQ FT FILTER AREA

LARGE, EASY ACCESS  
FILTER SERVICE DOOR

SUPER EFFICIENT  
FILTRATION

FILTER CONDITION  
INDICATOR GAUGE

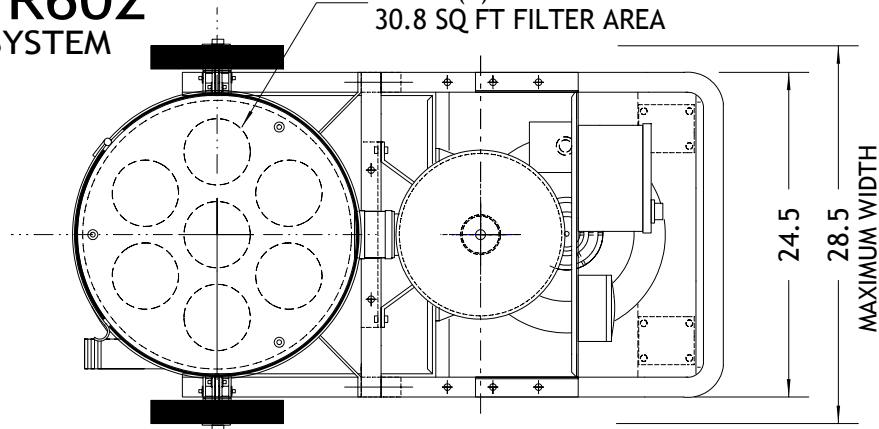

EFFECTIVE  
FILTER BAG  
SHAKER

FILTERS NEVER  
NEED CLEANING  
AS THE CANISTER  
FILLS.

OPTIONAL HEPA  
FILTER WITH  
CONDITION  
INDICATOR

OVERHEAD  
CRANE LIFT  
HOOKS

2.5" NPT  
INLET WITH  
INTERNAL  
WEAR STRIP

25.1 US GAL  
STORAGE DRUM

OPTIONAL EQUALIZER  
KIT ALLOWS GARBAGE BAG  
LINER IN DRUM

20" DIAMETER  
BAGHOUSE FILTER

12.0  
DIAMETER

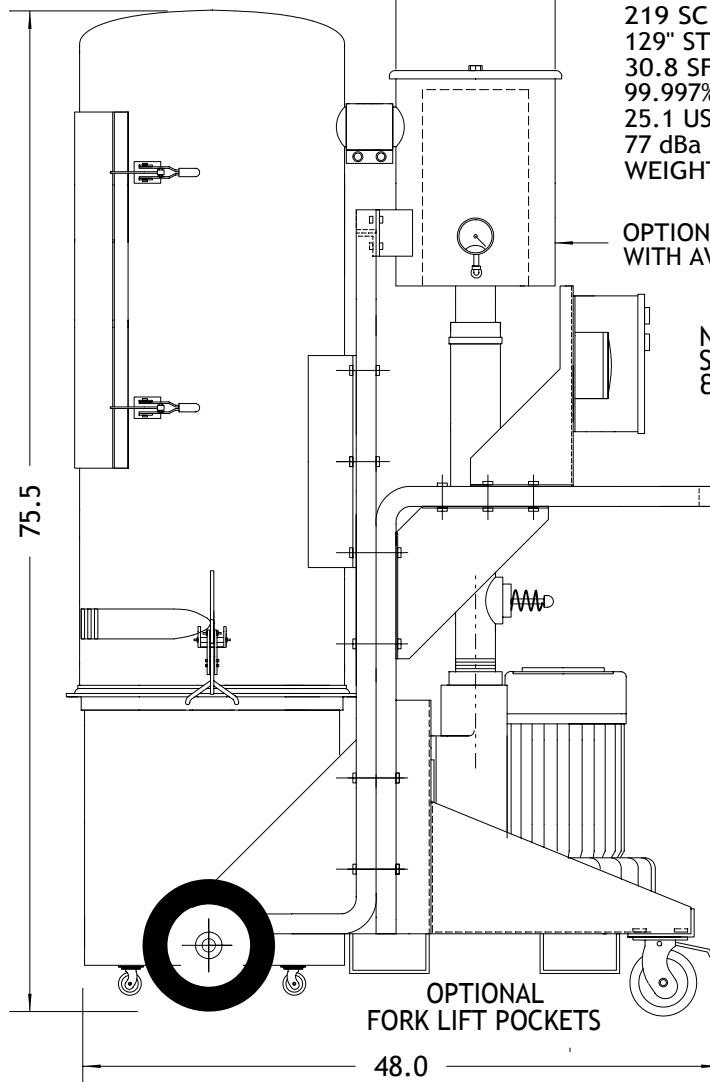

### SPECIFICATIONS:

6.1 HP MOTOR (VOLTAGE TO SUIT)  
219 SCFM MAX  
129" STATIC PRESSURE MAX  
30.8 SF FILTER BAGS  
99.997% @ 0.4 MICRON EFFICIENT  
25.1 US GALLON STORAGE DRUM  
77 dBa NOISE LEVEL  
WEIGHT 496 LBS

OPTIONAL INLINE FILTER  
WITH AVAILABLE HEPA UPGRADE

NEMA 4  
STARTER PANEL  
& DP GAUGE

HEAVY DUTY  
STEEL FRAME

VACUUM GAUGE  
& RELIEF VALVE  
STANDARD

6.1 HP  
QUIET, DEPENDABLE  
VACUUM PRODUCER

EFFECTIVE, BUILT-IN  
SILENCER

LOCKABLE  
5" SWIVEL CASTERS

			DATE:	FEB 2004	NORTHWIND AIR SYSTEMS BRAMPTON, ONTARIO
			DRAWN BY:	KRW	
			SCALE:	N.T.S.	
0	FEB 04	ISSUED FOR REVIEW	DRAWING No.	Rev.	<b>DuroVac</b> <b>DVR602</b>
No.	DATE	REVISIONS	4060332 - D02	00	