

# MODEL DV52

## 5.0 HP VACUUM SYSTEM

LARGE, EASY ACCESS  
FILTER SERVICE DOOR

SUPER EFFICIENT  
FILTRATION

FILTER CONDITION  
INDICATOR GAUGE

EFFECTIVE  
FILTER BAG  
SHAKER

FILTERS NEVER  
NEED CLEANING  
AS THE CANISTER  
FILLS.

OPTIONAL HEPA  
FILTER WITH  
CONDITION  
INDICATOR

OVERHEAD  
CRANE LIFT  
HOOKS

2.5" NPT  
INLET WITH  
INTERNAL  
WEAR STRIP

19.3 US GAL  
STORAGE DRUM

OPTIONAL EQUALIZER  
KIT ALLOWS GARBAGE BAG  
LINER IN DRUM

SIX (6) FILTER BAGS WITH  
20.9 SQ FT FILTER AREA

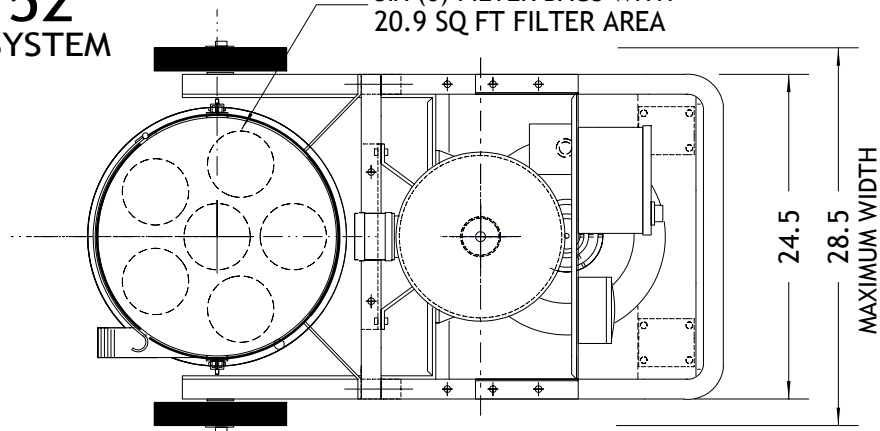

18" DIAMETER  
BAGHOUSE FILTER

### SPECIFICATIONS:

5.0 HP MOTOR (VOLTAGE TO SUIT)  
219 SCFM MAX  
113" STATIC PRESSURE MAX  
20.9 SF FILTER BAGS  
99.997% @ 0.4 MICRON EFFICIENT  
19.3 US GALLON STORAGE DRUM  
75 dBa NOISE LEVEL  
WEIGHT 426 LBS

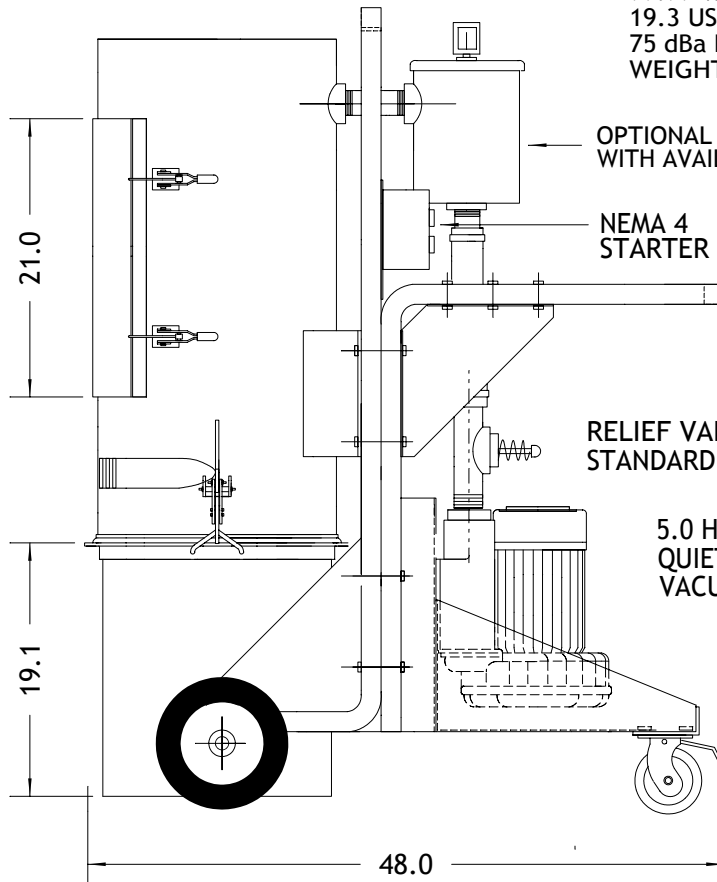

OPTIONAL INLINE FILTER  
WITH AVAILABLE HEPA UPGRADE

NEMA 4  
STARTER SWITCH

RELIEF VALVE  
STANDARD

5.0 HP  
QUIET, DEPENDABLE  
VACUUM PRODUCER

EFFECTIVE, BUILT-IN  
SILENCER

LOCKABLE  
5" SWIVEL CASTERS

|     |        |                   |             |          |   |
|-----|--------|-------------------|-------------|----------|---|
|     |        |                   | DATE:       | FEB 2004 |  |
|     |        |                   | DRAWN BY:   | KRW      |   |
|     |        |                   | SCALE:      | N.T.S.   |   |
| 0   | APR 04 | ISSUED FOR REVIEW | DRAWING No. | Rev.     | <b>CONTINUOUS DUTY<br/>VACUUM SYSTEM</b>  |
| No. | DATE   | REVISIONS         | DVD20402    | 00       |   |